

SOVIET PHYSICS

JETP

A translation of the Zhurnal Éksperimental'noi i Teoreticheskoi Fiziki.

Editor in Chief—P. L. Kapitza; *Associate Editors*—M. A. Leontovich, E. M. Lifshitz, S. Yu. Luk'yanov;

Editorial Board—É. L. Andronikashvili, K. P. Belov, V. P. Dzhelepov, E. L. Feinberg, V. A. Fock,

I. K. Kikoin, L. D. Landau, B. M. Pontecorvo, D. V. Shirkov, K. A. Ter-Martirosyan, G. V. Zhdanov (*Secretary*).

Vol. 23, No. 1, pp. 1-194

(Russ. Orig. Vol. 50, No. 1, pp 3-294, January 1966)

July 1966

EXPERIMENTAL INVESTIGATION OF THE PROPAGATION OF ULTRASOUND IN VISCOUS LIQUIDS

S. V. KRIVOKHIZHA and I. L. FABELINSKIĬ

P. N. Lebedev Physics Institute, Academy of Sciences, U.S.S.R.

Submitted to JETP editor July 20, 1965

J. Exptl. Theoret. Phys. (U.S.S.R.) 50, 3-14 (January, 1966)

Measurements were made of the velocity and absorption of 3 Mc ultrasound in triacetin and 1,2-propylene glycol, when the viscosity of these media changed by 7-9 orders of magnitude. It was established that a relaxation theory using one or several relaxation times was incapable of describing the observed relationships. An analytic dependence on the frequency and relaxation time was found experimentally in the region of the greatest change in the velocity and absorption. The main features of the observed effects, to be satisfied by a future theory of the propagation of sound in high-viscosity media, are formulated.

THE propagation of ultrasound and hypersound in some liquids with a large bulk coefficient and a small shear coefficient of viscosity are described well by a variant of the relaxation theory due to Mandel'shtam and Leontovich,^[1] which uses one relaxation time.^[2-5] In other cases, formulas with two or several relaxation times are needed to describe the propagation of sound.^[2-5]

The description of the propagation of sound is particularly complex for liquids whose shear viscosity coefficient rises from the usual values (fractions of a poise) to the viscosity of the glassy state ($\approx 10^{15}$ poises). In such cases, a relaxation theory with one or even several relaxation times is incapable of describing the propagation quantitatively. If the relaxation theory is nonetheless used to describe the propagation of sound in viscous liquids, a continuous spectrum of relaxation times

must be introduced. This approach was employed in a number of investigations.^[6-9] The distribution function of the relaxation times was not selected on the basis of independent experiments or a theory, but so as to fit the experimental results. The investigators using this approach pointed out that the selected distribution function was not unique. Therefore, the procedure for describing a distribution of relaxation times by empirical functions was not considered to provide a physical explanation of the observed process, but was only regarded as a useful device when different measurements on the same liquid were being compared. A similar situation occurs in the description of the frequency or temperature dependence of ϵ' and ϵ'' ^[8,9] in viscous media (dispersion of electromagnetic waves in polar liquids). This situation cannot be regarded as satisfactory.

There have been few experimental investigations of the velocity and absorption of ultrasound and hypersound in viscous liquids. Therefore, in the present study, we attempted to extend the range of investigated substances and to analyze our and similar investigations so as to formulate clearly the disagreement between experiment and the relaxation theory and to find experimental relationships which would have to be the first among those to be explained by any future theory of the propagation of sound in viscous media.

METHOD OF MEASUREMENT. EXPERIMENTAL CONDITIONS. ACCURACY OF MEASUREMENTS

The method used to investigate experimentally the propagation of sound in a medium whose viscosity varied over a wide range was based on a technique developed by Velichkina and one of the present authors.^[10] This method was improved so that the same apparatus could be used to measure the velocity of ultrasound as well as its absorption, using two variants of a pulse method. This still permitted the use of the absorption measurement method developed in^[10]. The block diagram of the apparatus is shown in Fig. 1.

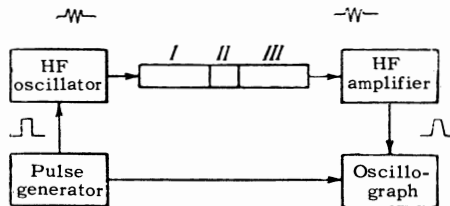

FIG. 1. Block diagram of the apparatus used to measure the velocity and absorption of ultrasound.

A high-frequency (1–3 Mc) oscillator was controlled by a pulse generator GIS-2. Pulses of 1–10 μ sec duration and 400 cps repetition frequency excited an x-cut quartz plate radiator, 0.1 mm thick, which was in acoustical contact with one end of a rod I. An acoustic pulse passed through the rod I, the investigated medium II, and a rod III made of the same material as the rod I (both rods were made of glass).

The end of the rod III was in contact with a receiver in the form of a piezoelectric quartz plate, of exactly the same dimensions as the radiator plate. The received and amplified pulses were detected and applied to the vertical plates of an oscillograph EO-7. The oscillograph scan was controlled by the same pulse generator. When an acoustic pulse reached the quartz receiver, the

oscillograph showed the envelope of the received pulse.

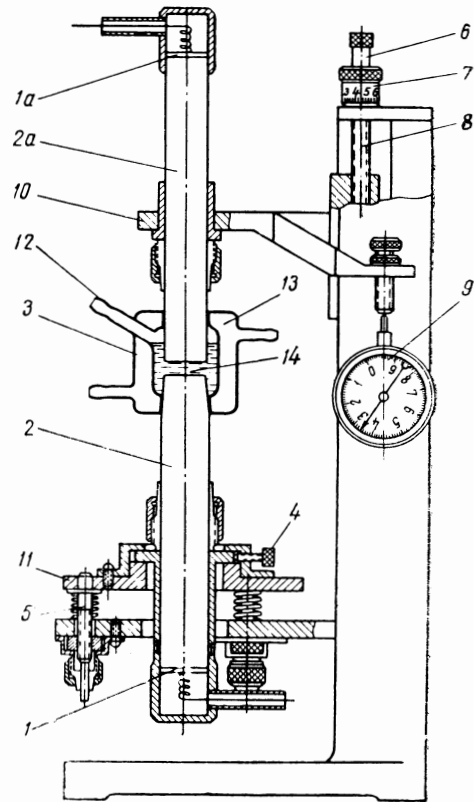

FIG. 2. Diagram of the mechanical part of the apparatus used to measure the velocity and absorption of ultrasound.

The apparatus (Fig. 2), when used in the variant developed by Velichkina for the measurement of the velocity and absorption of sound,^[10] was a multiple-beam acoustic interferometer. If the gap between the rods I and III is l the intensity of sound reaching the piezoelectric quartz receiver, after multiple reflection and interference, is given by the well-known formula^[11]

$$I = \frac{I_0}{\cos^2 kl + \frac{1}{4}(v_1 \rho_1 / v \rho + v \rho / v_1 \rho_1)^2 \sin^2 kl}. \quad (1)$$

Here, I_0 is the intensity of sound incident on the boundary separating the media I and II; k is the wave number of sound in the investigated medium II; $v_1 \rho_1$ is the wave impedance of the rods I and III. It follows from Eq. (1) that the signal at the acoustic receiver 1a (Fig. 2) will vary periodically with the thickness l of the medium II or, if the thickness l is constant, when the wavelength or frequency of sound is varied. The signal reaches a maximum value when $kl = n\pi$ (n is an integer) and a minimum value when $kl = (2n + 1)\pi/2$.

From the condition for a maximum, $kl = 2\pi fl/v = n\pi$, we obtain the velocity of sound

$$v = 2lf/n, \quad (2)$$

where n is the number of maxima observed on the oscillograph screen when the thickness of the medium II is varied from 0 to l , while from the condition for a minimum we find

$$v = 4lf/(2n + 1), \quad (3)$$

where n is the number of minima observed when the thickness of the medium II is varied from 0 to l . Thus, the velocity of sound may be found by a simple count of the number of maxima or minima when l is varied.

The measurement of the absorption by the method developed in [10] requires the measurement of the amplitudes of the maximum and minimum signals appearing on the oscillogram screen, the absorption coefficient α being given by the relationship

$$al + b = \tan^{-1}(A_{max}/A_{min}), \quad (4)$$

where b is a constant. The formulas (2) and (3) remain valid as long as $\alpha\lambda \ll \pi$. To measure the absorption by the pulse method, the distance between the rods I and III was increased to such a value that the transit time of sound through the investigated liquid layer was much longer than the pulse duration. Then there was no interference between the reflected waves in the layer II and, if the amplitudes of the transmitted sound A_1 and A_2 were measured for two different thicknesses l_1 and l_2 ($l_2 > l_1$) of the medium II, the absorption coefficient was given by the relationship

$$\alpha = \frac{1}{l_2 - l_1} \ln \frac{A_1}{A_2}. \quad (5)$$

If l was kept constant and measurements were made of the amplitude of the first maximum of a signal which traversed the layer l once and of the second maximum of a signal which traversed the layer three times, then

$$\alpha = \frac{1}{3l} \ln \left(\frac{1}{r^2} \frac{A_1}{A_2} \right), \quad r = \frac{\rho v - \rho_1 v_1}{\rho v + \rho_1 v_1}. \quad (6)$$

The change in the thickness of the layer l was measured with a dial indicator whose divisions represented 0.01 mm and 0.001 mm. Before each measurement of the velocity or absorption, the ends of the rods I and III facing the medium II under investigation were placed parallel to each other. The ends were made parallel to within 1/200-th of the wavelength of sound in water using a 5 mm thick Johansson block and adjusting

screws 5 (Fig. 2). The rods I and III were easily made coaxial by means of three screws 4 (Fig. 2). The thickness of the investigated liquid layer l was varied by moving a rod 2a by means of a coarse screw 6 and a micrometer screw 7 (Fig. 2).

The temperature of the investigated liquid was varied from +20 to +70°C by means of a Hoeppler ultrathermostat. The working substance of the ultrathermostat circulated between the walls of a chamber 3 made of quartz. Nitrogen, evaporated from a Dewar flask containing liquid nitrogen into which a heater had been lowered, was circulated between the walls of the chamber 3 to obtain temperatures in the range from +20 and -90°C. By varying the evaporation rate of nitrogen using the heater, we were able to establish the required temperature in the investigated liquid. The temperature was measured with a thermocouple specially sealed into a spur 12. The temperature did not change by more than 0.02 deg during the measurement of the velocity of ultrasound.

The velocity and absorption coefficient of ultrasound were measured between +40 and -80°C, for triacetin and between +40 and -100°C for 1,2-propylene glycol.

The accuracy of the measurements of the velocity and absorption coefficient for values of the viscosity $\eta < 5 \times 10^{12}$ P was 0.2 and 2.5%, respectively. At higher viscosities, the accuracy of the measurements of the velocity and absorption coefficient decreased to 0.5 and 5%, respectively.

RESULTS OF MEASUREMENTS

The results of the measurements of the temperature dependence of the velocity and absorption of ultrasound and of the measurements of the velocity in the hypersonic region [15] in triacetin are given in Table I and Fig. 3. Table I also lists the values of the viscosity, which was measured using a Hoeppler viscometer between +50 and -36°C and was determined using an extrapolation formula between -36 and -85°C.¹⁾

The nature of the temperature dependence was the same for the velocities of ultrasound and hypersonic, except that the region of the greatest change in the velocity of hypersonic was shifted toward higher temperatures. Figure 3 shows also that the limiting values of the velocity at zero (v_0) and in-

¹⁾According to Tamman's measurements, [12] the temperature dependence of the viscosity of triacetin is given by the following formula: $\log \eta = -a + b \times 10^3/(T - T_\infty)$ where $a = 4.14$, $b \times 10^3 = 340$, $T_\infty = 187^\circ\text{K}$.

Table I. Temperature dependence of the velocity and absorption of ultrasonic waves in triacetin; 3 Mc frequency

T, °C	v, m/sec		α, cm^{-1}	η, P	T, °C	v, m/sec		α, cm^{-1}	η, P
	ultra-sound	hyper-sound				ultra-sound	hyper-sound		
+72		1246			-34			11.1	
+50			0.14	0.058	-34			10.8	
+42			0.14		-35.5	1679			1250
+42.6				0.08	-36			11.3	
+31.5				0.12	-37.5			13.6	
+32.5			0.142		-39	1780		14.7	
+22				0.2	-39	1780		14.4	1840
+20	1439	1616			-40		2536		
+16	1454				-41			14.4	
+13	1454				-41			14.7	
+10	1461		0.146		-41.5	1932			
+8				0.45	-42			13.8	
+5.7				0.149	-43			13.3	
+5	1475				-44	2030		12.3	
0	1482	2065	0.157	0.9	-44	2030		12.5	
-4				1.41	-46	2162		11.8	
-5	1518		0.192		-51			6.8	
-9.6			0.193		-52			6.5	
-10	1530				-54			4.05	
-13.5			0.355	4.61	-55	2510			
-15	1550	2386		4.68	-57			1.72	
-18	1565				-60	2570	2718		
-20				26.3	-62	2586			
-22			1.89		-64	2600		0.33	
-22.5			2.21		-65			0.33	
-24	1590				-67	2618			
-24.5			2.82		-69	2626			
-24.5			2.74		-71.5	2640		0.212	
-27	1619		3.45	125	-72.5	2648			
-30	1625			282	-74.5			0.255	
-32	1645		6.5		-75	2650			
-33				630	-82.5			0.137	

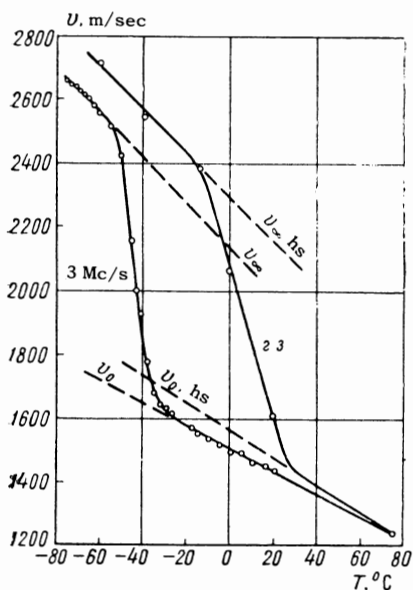
**FIG. 3.** Temperature dependence of the velocity of propagation of ultrasound and hypersonic (hs) in triacetin.

finite (v_∞) frequencies had different temperature coefficients:

$$\Delta v_0 / \Delta T < \Delta v_\infty / \Delta T.$$

Figure 4 shows the temperature dependence of the amplitude absorption coefficient of triacetin.

The curve has a strong maximum at -40°C .

Table II, Fig. 5 and Fig. 6 give the data of the measurements of the velocity and absorption of ultrasound in 1,2-propylene glycol. Table II also contains the values of the viscosity measured between $+40$ and -42°C . Between -42 and -95°C , the viscosity was found using an extrapolation formula.²⁾ The nature of the temperature dependence of the velocity was the same as for triacetin, and again $\Delta v_0 / \Delta T < \Delta v_\infty / \Delta T$.

Figure 6 shows the temperature dependence of the absorption coefficient of 1,2-propylene glycol with a maximum at -51°C . Similar temperature dependences of the velocity and absorption of ultrasound have been reported for other cases.^[6,7,13-15]

DISCUSSION OF RESULTS

As already mentioned, we shall not try to describe our results by introducing a spectrum of relaxation times, but we shall use the formulas of the relaxation theory with one relaxation time

²⁾To extrapolate the viscosity of 1,2-propylene glycol, we employed a formula similar to the extrapolation formulas used in [7] for the viscosity: $\log \eta = -a + b/(T - T_c)^3$, where $a = 8.1$, $b = 1.85 \times 10^8$.

Table II. Temperature dependence of the velocity and absorption of ultrasonic waves in 1,2-propylene glycol; 3 Mc frequency

$T, ^\circ\text{C}$	$v, \text{m/sec}$	α, cm^{-1}	η, P	$T, ^\circ\text{C}$	$v, \text{m/sec}$	α, cm^{-1}	η, P	$T, ^\circ\text{C}$	$v, \text{m/sec}$	α, cm^{-1}	η, P
+40		0,15	0,158	-30		2,97	104,5	-54		17,2	
+31,5		0,156	0,24	-32	1786			-54		16,5	
+22		0,52		-32,5		3,1		-55		17,1	
+20,5	1533			-34			185,6	-55,5	2364		
+18,2		0,154		-36		4,6		-57		11,5	
+10		0,266		-36,5	1866			-57		12,2	
+8		0,29		-37,5			439	-59	2529		
+5			1,7	-38,5			573	-60		6,93	
-0,5	1651			-39,5	1886			-62		5,0	
-4	1660			-41,5	2026			-65	2710		
-7	1681			-42			1226	-70	2862		
-8			6,43	-43		11,2		-71		1,72	
-9,5	1684			-44		11,3		-72,5	2912		
-12,5	1693		10,5	-47	2114			-76	2931		
-15	1699			-48		17,6		-80	2999		
-17	1716	0,63		-48,5	2292			-82,5		0,307	
-20		13,1	21,4	-50,5		20,4		-85		0,195	
-21	1705			-51	2340			-87	3068		
-24		1,88		-51		20,9		-89	3080		
-25		2,56	43,7	-52		20,3		-92		0,193	
-27	1748			-53		19,8		-95		0,133	

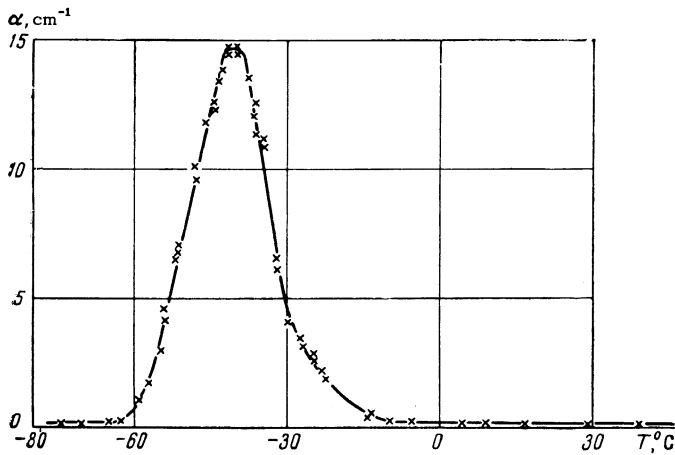

FIG. 4. Temperature dependence of the absorption coefficient of ultrasound in triacetin.

in order to facilitate the determination of the real relationships governing the propagation of ultrasound in viscous media. For this purpose, the relaxation theory formulas^[1,4] are transformed into the following form:

$$y = \frac{C}{1-C} = \Omega^2 \tau^2, \quad C = \frac{v^2 - v_0^2}{v_\infty^2 - v_0^2}, \quad (7)$$

where Ω is the frequency of sound, τ is the relaxation time, and

$$y' = \frac{C'(v_\infty/v_0)^2}{1 - v_\infty/v_0 - C'} = \Omega^2 \tau^2, \quad C' = 2\alpha\tau v. \quad (8)$$

The formulas (7) and (8) are convenient because the dependence of y and y' on τ^2 and Ω^2 is linear and because Ω and τ occur in the formulas in the

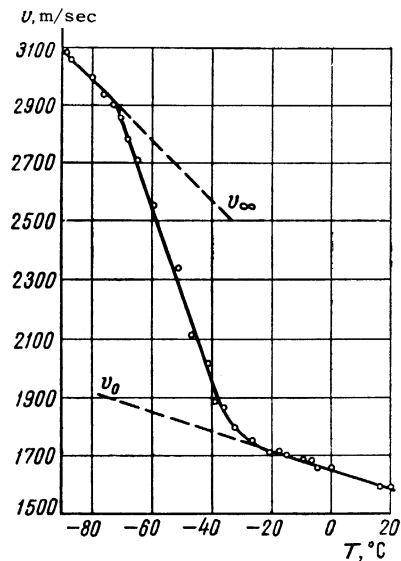

FIG. 5. Temperature dependence of the velocity of propagation of ultrasound in 1,2-propylene glycol (3 Mc).

form of a product. Therefore, it is quite unimportant whether the frequency or the relaxation time is varied; in both cases, the theory predicts the same linear dependence of y and y' on τ^2 and Ω^2 .

The experimental material was analyzed in accordance with the formulas (7) and (8). In the experiments described, the frequency of the ultrasound was kept constant and only the temperature of the liquid was varied. When the absolute temperature was altered by a factor of about 2, the viscosity of the investigated media changed by many orders of magnitude (cf. Tables I and II).

The relaxation theory assumes that τ is some

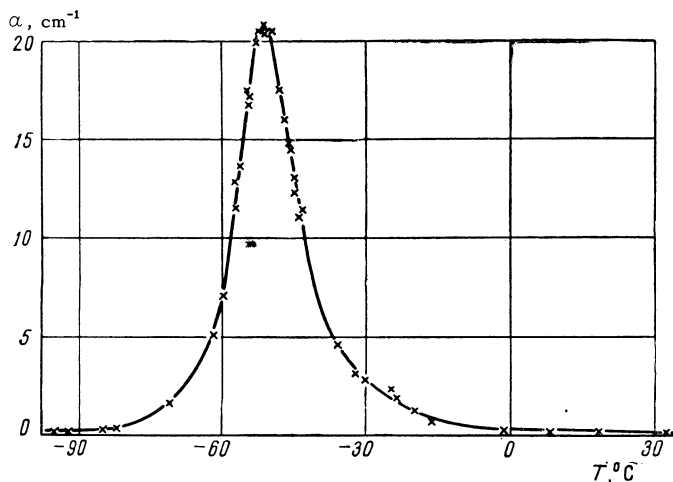

FIG. 6. Temperature dependence of the absorption coefficient of ultrasound in 1,2-propylene glycol.

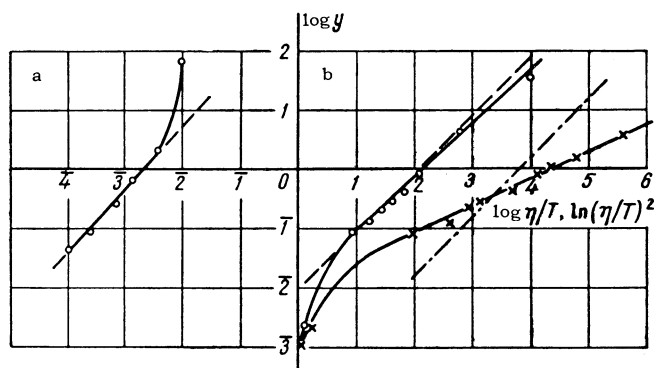

FIG. 7. Dependence of $\log y$ on $\log \tau^2$ for triacetin: a) hypersonic; b) ultrasound; \times - Experimental data, $\tau \propto \eta/T$; \circ - experimental data, $\tau \propto \sqrt{\eta/T}$; dash-dot line - calculated data, $\tau \propto \eta/T$; dashed line - calculated data, $\tau \propto \sqrt{\eta/T}$.

parameter which is not related to the measured quantities such as the viscosity, temperature, or the velocity of sound. To analyze the material obtained, it was necessary to make some definite assumptions about the dependence of the relaxation time on the viscosity and temperature. We assumed that³⁾

$$\tau = B\eta / T. \tag{9}$$

The right-hand part of Fig. 7⁴⁾ shows the dependence of $\log y$ on $\log (\eta/T)^2$ based on the experimental data for triacetin (crosses and continuous curve), as well as the theoretical straight line

³⁾Formula (9) represents a variant of the well-known formula for the time relaxation of a dipole moment, [16,17] $\tau = 4\pi a^3 \eta / 3kT$ and the temperature dependence differs little from the formula assumed in some ultrasonic investigations: [18] $\tau = 4\eta / 3v_0^2 \rho$.

⁴⁾Here, and in Figs. 8-14, common (\log_{10}) logarithms are used.

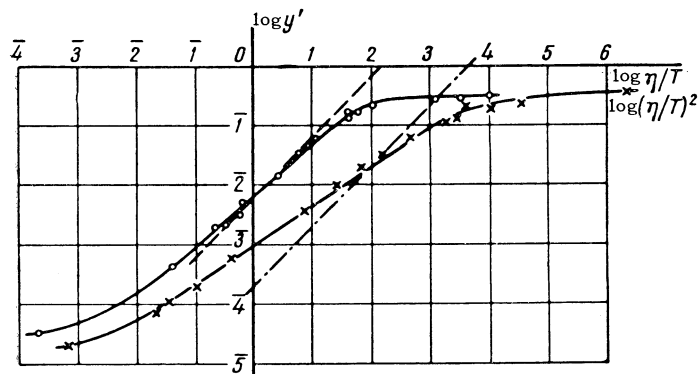

FIG. 8. Dependence of $\log y'$ on $\log \tau^2$ for triacetin. The notation is the same as in Fig. 7.

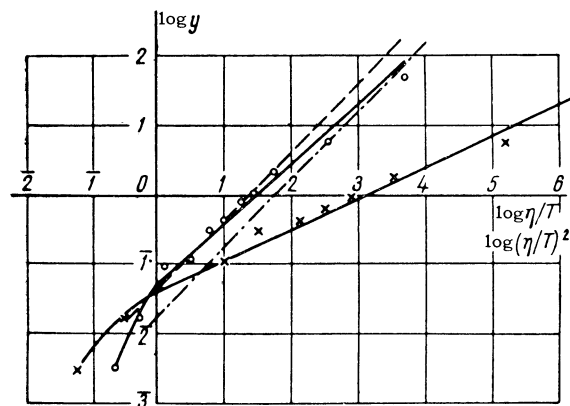

FIG. 9. Dependence of $\log y$ on $\log \tau^2$ for 1,2-propylene glycol. The notation is the same as in Fig. 7.

(chain line). The slopes of this straight line and of the rectilinear part of the experimental curve are different, but it is worth noting that the experimental data, plotted in the coordinates $\log y$ and $\log (\eta/T)^2$, are described by a straight line in the region of the greatest change in the velocity. The points obtained in the region of the slow change in the velocity depart from a straight line (Fig. 7). The same is observed for the dependence of y' on τ for triacetin (Fig. 8). Here, as in the case of the velocity of ultrasound (Fig. 7), the theoretical and experimental data fit straight lines with markedly different slopes. Similar relationships are observed in the case of 1,2-propylene glycol (Figs. 9 and 10).

The data from the measurements of other workers, analyzed in the same way as for triacetin and 1,2-propylene glycol, gave similar results in all cases. As examples, Figs. 11 and 12 give the results of an analysis of the measurements on glycerin^[6,13] and 1,3-butanediol.^[7]

Thus, in the selected coordinates (Figs. 7-12), all the known results for the region of a strong variation in the velocity and absorption of ultra-

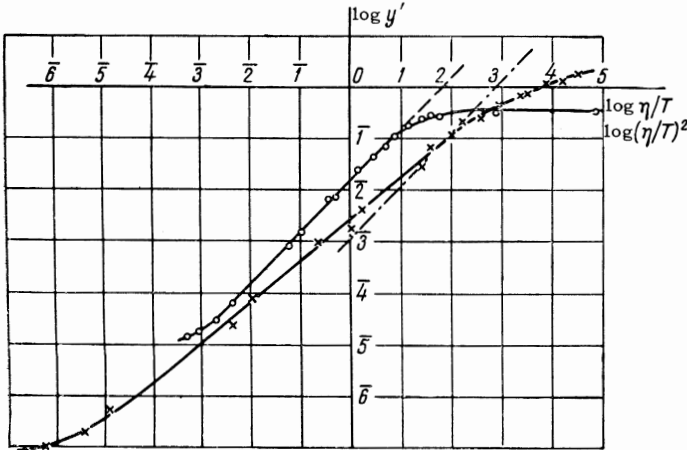

FIG. 10. Dependence of $\log y'$ on $\log \tau^2$ for 1,2-propylene glycol. The notation is the same as in Fig. 7.

sound give a linear dependence of y and y' on τ^2 . In all cases, the slope of the straight line representing the experimental data is less than the slope of the theoretical line. Therefore, it is natural to consider what changes must be made to Eqs. (7), (8) and (9) to make them describe the experimental straight lines.

It can easily be seen that to make an experimental straight line coincide with a theoretical line (Figs. 7–12), the latter should be turned through a certain angle (in our logarithmic coordinates, such rotation represents a change of the power exponent of the quantity η/T). If we assume that

$$\tau = b(\eta/T)^n, \quad (10)$$

then we must have $n \approx 1/2$ if the theoretical straight line is to describe satisfactorily the experimental results. Figures 7–12 show the experimental (continuous lines with points) and theoretical (dashed) lines plotted on the assumption that τ is given by Eq. (10) with $n = 1/2$. These theoretical lines coincide with the experimental ones within the limits of the experimental error.

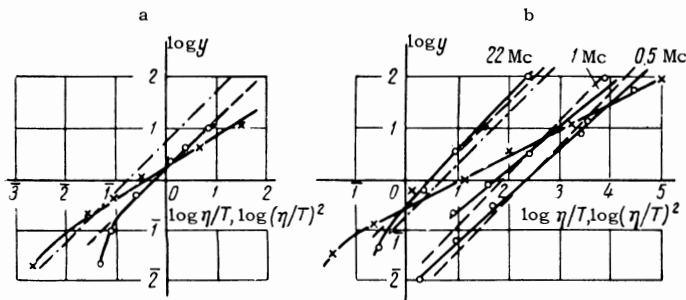

FIG. 11. Dependence of $\log y$ on $\log \tau^2$ for 1,3-butanediol (a) and glycerin (b). The notation is the same as in Fig. 7.

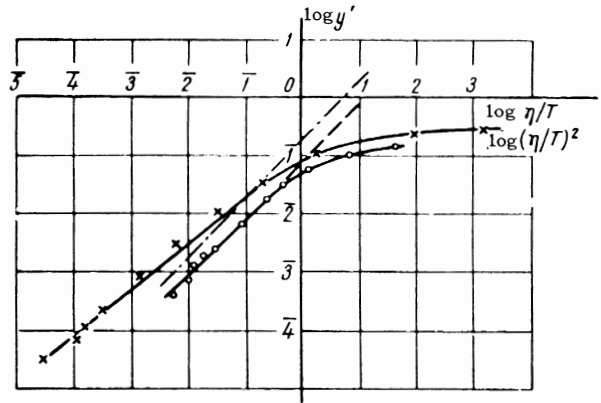

FIG. 12. Dependence of $\log y'$ on $\log \tau^2$ for glycerin. The notation is the same as in Fig. 7.

Satisfactory agreement between the calculations and the experimental data is obtained in all cases, both for our measurements and the measurements of other investigators^[6,7,13,14] analyzed by our method (Figs. 7–12). If however, the dependence of the relaxation time τ on the viscosity and temperature is retained in the form given by Eq. (9), and if it is taken into account that the quantities τ and Ω are of equal importance in Eqs. (7) and (8), then instead of Eqs. (7) and (8) we ought to write

$$y = \Omega\tau, \quad y' = \Omega\tau. \quad (11)$$

The formulas (11) will describe satisfactorily the experimental results only in the region where the velocity and absorption of sound vary rapidly.

It should be mentioned that the formulas (11) not only do not follow from the relaxation theory but they are incompatible with this theory. They can be regarded, for the time being, as an incomplete formulation of the relationships observed for the propagation of ultrasound in viscous media. We shall mention other experimental results which cannot be explained by the relaxation theory using a limited number of relaxation times.

The dependence α/f^2 on f has the same form as the dependence of α/τ on $\tau = B(\eta/T)$. The relaxation theory requires that the maximum of the dependence of $\alpha\lambda$ on $\tau = B(\eta/T)$ should coincide exactly with the middle of the curve giving the dependence of α/τ on τ . In fact, this maximum is strongly displaced toward higher values of τ , which is illustrated in Fig. 13. Moreover, the width and the amplitude of the maximum in the experimental $\alpha(\tau)$ curves are, respectively, much greater and lower than the values required by the relaxation theory (Fig. 14).

On the basis of the investigation carried out and the discussion of the results, we are inclined to the opinion that the relaxation theory using one or

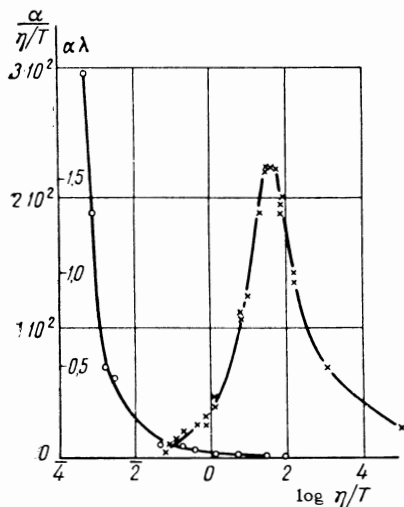

FIG. 13. Dependence of α/τ (circles) and $\alpha\lambda$ (crosses) on $\log \eta/T$ for 1,2-propylene glycol.

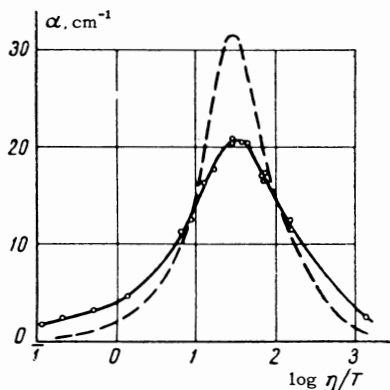

FIG. 14. Temperature dependence of the absorption coefficient of 1,2-propylene glycol: the continuous curve represents the experimental data; the dashed curve gives the calculated data calculated using the formulas of the relaxation theory with one τ .

even several relaxation times is unsuitable for the explanation of the experimental results obtained. The same conclusion was reached by the investigators who described their results by a continuous spectrum of relaxation times.^[4-7] A future physical theory, avoiding the use of a relaxation time spectrum, should, first of all, explain the experimental relationships given by the formulas (11) and should describe the departure from the linear dependence of y and y' on τ and Ω outside the region of the strong variation in the velocity and absorption of sound. Moreover, it should explain the position, amplitude and width of the observed maximum (Figs. 13 and 14) and explain the difference between the temperature coefficients of the velocities v_0 and v_∞ .

The results of our experiments, which were completed over a year ago, were communicated

to Isakovich and Chaban, who developed a nonlocal diffusion theory of the propagation of ultrasound in viscous media to explain the relationships obtained. The formulas of the phenomenological theory of Isakovich and Chaban^[19] describe well all the features set out above and observed in the investigation of the propagation of ultrasound in viscous liquids. The new nonlocal theory uses only one relaxation time, which is governed by the bulk and shear viscosities, the limiting values of the velocities, and the density of the medium.

The new theory makes it necessary to carry out a series of new ultrasonic experiments and to continue the theoretical and experimental investigation of the nature of the nonuniform liquid whose model forms the basis of the theory.⁵⁾ The most important, in our opinion, is a check on the theoretical prediction of the nonuniformity of the liquid. Future investigations will show whether this nonuniformity represents structure fluctuations or some other phenomenon. Investigations of the scattering of neutrons in viscous liquids may help in solving this problem.

⁵⁾A detailed description of the theory and its comparison with experiment will be published later in this journal.

¹L. M. Mandel'shtam and M. A. Leontovich, JETP 7, 438 (1937).

²I. L. Fabelinskiĭ, UFN 63, 355 (1957); UFN 77, 649 (1962), Soviet Phys. Uspekhi 5, 667 (1963); UFN 87, 9 (1965), Soviet Phys. Uspekhi 8, 637 (1966).

³M. S. Pesin, Trudy FIAN (1965).

⁴K. F. Herzfeld and T. A. Litovitz, Absorption and Dispersion of Ultrasonic Waves, Academic Press, New York-London, 1959.

⁵I. G. Mikhaĭlov, V. A. Solov'ev, and Yu. P. Syrnikov, Osnovy molekulyarnoĭ akustiki (Fundamentals of Molecular Acoustics), Nauka, 1964.

⁶R. Piccirelli and T. A. Litovitz, J. Acoust. Soc. Am. 29, 1009 (1957).

⁷R. Meister, C. J. Marhoeffler, R. Sciamanda, R. Cotter, and T. A. Litovitz, J. Appl. Phys. 31, 854 (1960).

⁸D. W. Davidson and R. H. Cole, J. Chem. Phys. 19, 1484 (1951).

⁹W. F. Brown, Jr., Dielectrics, Handb. Physic. v. 17, Springer, 1956.

¹⁰T. S. Velichkina and I. L. Fabelinskiĭ, DAN SSSR 75, 177 (1950); T. S. Velichkina, Trudy FIAN 9, 59 (1958).

¹¹Baron Rayleigh (J. W. Strutt), Theory of

Sound, 1894-96 (Russ. Transl., Gostekhizdat, 1953, Vol. 2).

¹²G. Tamman, *Stekloobraznoe sostoyanie* (Glassy State), Gostekhizdat, 1935.

¹³A. K. Schulz, *J. Chim. Phys.* **51**, No. 10, 530 (1954).

¹⁴T. A. Litovitz, T. Lyon, and L. Peselnick, *J. Acoust. Soc. Am.* **26**, 566 (1954).

¹⁵M. S. Pesin and I. L. Fabelinskiĭ, *DAN SSSR* **135**, 1114 (1960), *Soviet Phys. Doklady* **5**, 1290 (1961).

¹⁶M. A. Leontovich, *J. Phys. USSR* **4**, 499 (1941).

¹⁷P. Debye, *Polar Molecules* (Russ. Transl., GTTI, 1931).

¹⁸R. Lucas, *Compt. Rend.* **206**, 658 (1938).

¹⁹M. A. Isakovich and I. A. Chaban, *DAN SSSR* **165**, 299 (1965), *Soviet Phys. Doklady* (in press).

Translated by A. Tybulewicz

1