

MUON GROUPS NEAR THE AXIS OF AN EXTENSIVE AIR SHOWER

Yu. N. VAVILOV, G. I. PUGACHOVA, and V. M. FEDOROV

P. N. Lebedev Physics Institute, Academy of Sciences, U.S.S.R.

Submitted to JETP editor September 13, 1962

J. Exptl. Theoret. Phys. (U.S.S.R.) 44, 487-492 (February, 1963)

The results of a search of narrow groups of μ mesons near the axis of extensive air showers with a number of particles $10^3 \leq N \leq 10^5$ are presented. It is shown that if μ -meson groups with a diameter ≤ 8 cm do exist, their frequency of appearance is at least 70 times smaller than that according to [3,4]. Data are presented which indicated that there is no genetic relation between μ mesons moving at distances ≤ 0.3 m apart.

THE observation of muon groups with different diameters in the composition of extensive air showers (EAS), as reported in [1-5], is of great interest to elementary-particle physics. This is connected in particular with the fact that the occurrence of such groups¹⁾ within the framework of the presently accepted pattern of high-energy nuclear interactions is far from trivial.

To obtain further information on muon groups in extensive air showers, the experimental array shown in Fig. 1 was developed. The installation was situated near sea level (Moscow). The muon detector employed was a large multiplate cloud chamber [6] placed under a large Cerenkov counter [7]. In the exposed region of the chamber, which measured $80 \times 60 \times 30$ cm, there were seven brass plates each 2 cm thick, amounting to 120 g/cm^2 of matter. The use of a cloud chamber with such plates as a detector offers much greater possibility of identifying the muon groups than screened hodoscope counters or a diffusion chamber, as used in [2-5].

The Cerenkov counter (height 5 meters, diameter of lower base 6.5 meters), in which the radiator employed was water purified in special equipment, was used for a more effective separation of the events in which EAS axis passed near the center of the array. At the same time, the water filling the counter served as a filter to absorb the nuclear-active and electron-photon components of the EAS. To increase the absorption of the electron-photon cascades produced as a result of the decay of the π^0 mesons produced in the nuclear high-energy interaction in the water of the Cerenkov counter, a layer of lead 16.5 cm was placed between it and

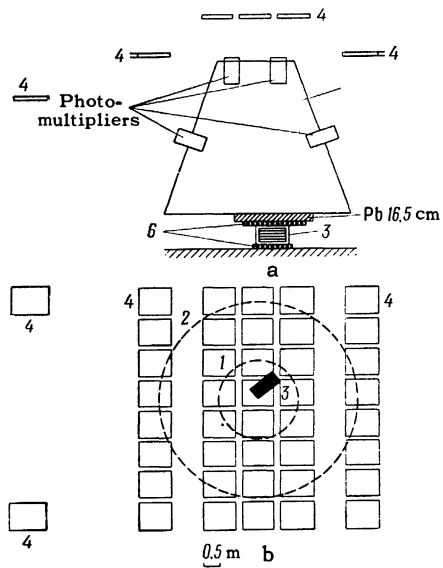

FIG. 1. Diagram of array: a - side view; b - top view. 1, 2 - upper and lower covers of the Cerenkov counter, 3 - cloud chamber, 4 - trays with hodoscope counters, 5 - Cerenkov counter, 6 - Geiger-Muller counters.

the chamber. Thus, the total amount of matter above the cloud chamber (including the 5-meter layer of water in the Cerenkov counter) was 700 g/cm^2 .

To determine the size and axis location of the shower striking the array, 1920 hodoscopic counters²⁾ were placed on the top cover of the Cerenkov counter, in a square measuring $8 \times 8 \text{ m}^2$. In addition, two groups of 48 counters each were located 8 meters away from the center of the array (see Fig. 1a). This arrangement of the hodoscopic counters makes it possible to locate the axis of an EAS striking the array within 10 meters from the center.

¹⁾Provided separate selection is made of groups which are not the consequence of Poisson fluctuations in the muon flux of the extensive shower incident on the array.

²⁾The effective area of each counter was 0.01 m^2 .

The apparatus was triggered by triple coincidence of the pulse A from the Cerenkov counter (provided the energy released in it exceeds 40 BeV³) with pulses B and C from the counter rows located above and below the cloud chamber, respectively. The BC coincidence was necessary to increase the efficiency with which the chamber registered the penetrating particles.

With the array so triggered, it registered some 6000 frames in 1100 hours of "net" measurement time (with account of the 4 minutes necessary to reset the chamber). Tracks of penetrating particles

were observed on the cloud-chamber photographs obtained thereby in the overwhelming majority of cases (≈ 97 per cent). Of all the registered events, we selected the cases when the photographs disclosed parallel tracks of particles penetrating without scattering (accurate to $\leq 1^\circ$) through all the plates of the chamber. Parallelism of the muon tracks was established within the accuracy that the angle between them could be measured, namely $\leq 1^\circ$ in the plane of the front window of the chamber and $\leq 4^\circ$ in the perpendicular direction. The results of the selection were as follows:

n_μ —number of muons in the group:	2	3	4
Number of registered groups with specified n_μ :	20	5	2
Average size of registered EAS:	$1.8 \cdot 10^4$	$2.2 \cdot 10^4$	$1.5 \cdot 10^4$
Average distance of the center of the group from the EAS axis, meters:	4.8	1.7	3.9
Average diameter of the group, cm:	20	24	39
Average zenith angle of the muon group, deg:	21	15	22.5

The integral distribution of the showers $F(>N)$ with respect to the total number of particles in the shower, for all the registered frames, is shown in Fig. 2. In addition to the cases which have been included in the spectrum of Fig. 2, the array registered also showers with $N < 10^3$ and $N > 5 \times 10^5$, but owing to the fact that the particle density in such showers is too small in one case and too large in the other to determine the location of the shower axis, the number of particles in these showers were not determined. The number of such events for $N < 10^3$ amounts to 30 per cent of the total number of registered frames, while for $N > 5 \times 10^5$ it amounts to 15 per cent.

Among the selected frames of parallel mesons, not a single event was observed that could be treated as a passage through the chamber of a parallel beam consisting of three and more particles with dia-

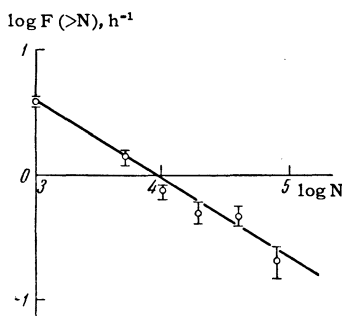

FIG. 2. Integral particle-number spectrum of the EAS registered by the array.

meter ≤ 8 cm, similar to that reported by Vernov et al^[4].

In order to determine the number of muon beams with diameter ≤ 8 cm that should be registered in our array, if their intensity is assumed to correspond to the data of^[4], it is necessary to take into account the differences in the triggering of the two arrays. In^[3,4] the beams were registered with a diffusion chamber, the operation of which was independent of the passage of any particles of the extensive shower through it. Our array was triggered only if at least one penetrating particle passed through the effective area of the cloud chamber. In addition, since the muon groups were located in accord with the data of^[3,4] near the axis of the EAS (60 per cent of the beams were observed at distances < 4 meters from the shower axis^[4]), we introduced the requirement that a definite minimum energy be released in the Cerenkov-counter radiator, equal to 40 BeV. The EAS spectrum registered by our array when triggered only by a pulse from the Cerenkov counter (with an energy release ≥ 40 BeV) is shown in Fig. 3⁴⁾.

To compare the observation results we take from the data of^[4] the intensity of the muon groups entering a circle of radius 4 meters from the center of the array for showers with $5 \times 10^3 \leq N \leq 10^5$. This region is chosen in connection with the fact that our array, as can be seen from Figs. 2–4, registers most effectively precisely these cases.

³⁾The value of this threshold was determined from calibration measurements with muons.^[7]

⁴⁾This spectrum was determined by a special series of measurements.

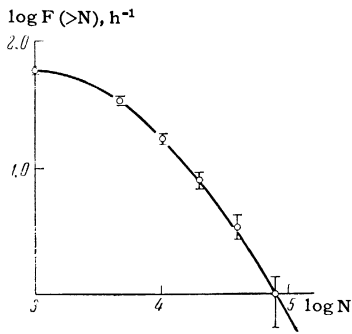

FIG. 3. Integral particle-number spectrum of the EAS when the array is triggered by events with energy ≥ 40 BeV released in the Cerenkov counter.

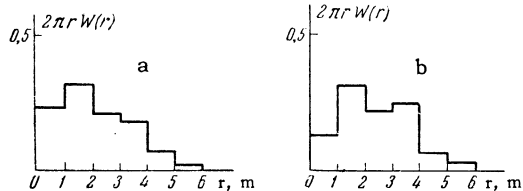

FIG. 4. Distribution of the EAS axes relative to the center of the Cerenkov counter. Abscissas – distance from the shower axes to the center of the Cerenkov counter, ordinates – relative number of axes entering into the ring ($r, r+dr$): a – distribution obtained in the “working” series of measurements (triggering by ABC pulse coincidence), b – distribution obtained when the array was triggered only by events with ≥ 40 BeV released in the Cerenkov counter.

The lateral distribution of the shower axes registered by the array of $[3,4]$ relative to the center of the control system (with the diffusion chamber located at the center), which we need for the comparison, was calculated by us ⁵⁾ and is shown in Fig. 5.

The total intensity of the groups, according to $[4]$, amounts to not less than 0.06 EAS/h-m^2 . ⁶⁾ If we take into account the distribution of Fig. 5 ⁷⁾, then the intensity per shower of the muon groups observed in the array of $[3,4]$ in EAS with $5 \times 10^3 \leq N \leq 10^5$ at distances ≤ 4 meters from the axis will be $0.06 \times 0.6 \times 0.6 \approx 0.02 \text{ h}^{-1} \text{ m}^{-2}$. Thus, the number n_μ of the groups which should be registered by our array is given by the expression

$$n_\mu = J_0 N_0 S t, \quad (1)$$

where J_0 is the intensity of the muon groups per

⁵⁾According to data provided by G. V. Kulikov.

⁶⁾In this case 60 per cent of the groups was in showers with $N \leq 10^5$.

⁷⁾It was found during the course of calculating the curve of Fig. 5 that 40 per cent of the shower axes registered by the array of $[3,4]$ at distances ≤ 4 meters from the center of the control system pertained to the range $5 \times 10^3 \leq N \leq 10^5$. Since in accordance with Fig. 5 the number of all the EAS in a circle with radius 4 meters amounts to 2 h^{-1} , the number of EAS with $5 \times 10^3 \leq N \leq 10^5$, registered in the same circle, will be $\approx 1 \text{ h}^{-1}$.

FIG. 5. Lateral distribution of shower axes registered by the array of $[3,4]$, r – distance from the shower axes to the center of the location of the triggering groups of counters.

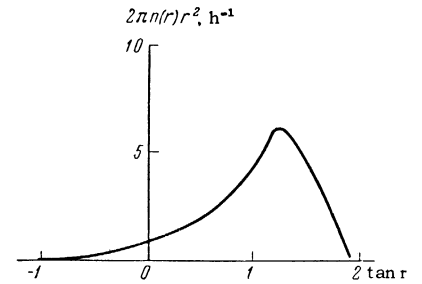

shower, as calculated above; N_0 is the frequency of the EAS registered in accordance with the spectrum of Fig. 3 for the interval $5 \times 10^3 \leq N \leq 10^5$; S is the effective area of the cloud chamber for mesons passing through all the brass plates, determined with allowance for the angular distribution of the beams, which is assumed to coincide with the angular distribution of the EAS axes, that is, $\cos^8 \theta$; t is the measurement time. Substituting the values $J_0 = 0.02$, $N_0 = 30$, $t = 1100 \text{ h}$, and $S = 0.1$ into the expression (1) we obtain $n_\mu \approx 70$.

On the basis of the foregoing calculations we can conclude that if the narrow beams observed in $[3,4]$ actually exist and are due to muons, then their intensity is at least ~ 70 times smaller than the intensity estimated in $[4]$.

The results of the selections, given above, enable us to draw also some conclusions concerning muon groups with diameter $\approx 30 \text{ cm}$, which were reported in $[1,2,5]$.

The lower energy limit of the muons contained in the 27 groups of parallel tracks which we selected ⁸⁾ can be estimated from the formulas for multiple scattering $[8]$. For the indicated layer of matter and for a scattering angle $\leq 1^\circ$, the muon energy on entering the cloud chamber should be $\geq 3.5 \text{ BeV}$. Taking into account the ionization losses in the Cerenkov counter and in the lead, we find that the energy of these muons in air, as they enter the Cerenkov counter, should be at least 5 BeV . This estimate of the muon energy agrees with the data on the energy spectrum of the muons at different distances from the axis of extensive air showers, as obtained by Bennett and Greisen $[9]$: according to $[9]$, for a distance of 5 meters from the axis, the energy spectrum of the muons should be such that ≈ 70 per cent of the muons should have an energy $\geq 5 \text{ BeV}$.

⁸⁾We note that when the angle between the tracks of the penetrating particles in the cloud chamber is 1° and the distance between them is 10 cm , the point where the continuation of these tracks intersect lies above the upper cover of the Cerenkov counter, so that it is little likely that these tracks belong to the products of nuclear interactions in the Cerenkov counter.

In order to ascertain whether genetic relations are observed for the muons contained in our registered groups of two or more parallel tracks, we plotted for all these groups the distribution over the distances between the tracks as projected on the plane of the upper cover of the cloud chamber. This distribution was compared with the distribution obtained by assuming statistical independence of the muon trajectories in the EAS, in the following fashion. The effective area of the cloud chamber was broken up into a definite number of identical rectangles⁹⁾, each identified with some number. Then, using a table of random numbers, we obtained the distribution over the distances between pairs of muon trajectories for a number of artificial pairs equal to the experimentally registered number of pairs of parallel tracks plus a number of pairs equal to the number of all possible combinations of two for the experimentally obtained number of cases with three and four parallel tracks.

To take into account the reduction in the effective area of the cloud chamber when inclined groups of muons passing through all seven plates are registered, the play of the number of distributions among the muon trajectories in accordance with the random-number table was made for an effective area reduced compared with the area for the vertical incidence.

The effective area S was determined from the formula *

$$S = S_0 \left(1 - \frac{h}{l} \operatorname{tg} \theta\right) \cos \theta \left(1 - \frac{h}{a} \operatorname{tg} \theta'\right) \cos \theta'.$$

Here l —length of the exposed region of the cloud chamber, a —depth of the exposed region, h —height of the exposed region, θ —angle of inclination of the muon group to the vertical projected on the plane of the forward window of the cloud chamber, θ' —angle of inclination between the group of muons and the vertical, projected on the plane of the side window of the cloud chamber, and $S_0 = al$ —area of the chamber for the case $\theta = \theta' = 0$.

The experimentally obtained distribution of distances between pairs of muons, and also the distribution calculated with the aid of the random-number table, are shown in Fig. 6.

We see that agreement is observed between the experimentally obtained distribution and the calculated one. This enables us to state that in showers with $10^3 \leq N \leq 10^5$ there is no noticeable number of events of genetically related groups of two and more muons with diameter ≤ 3 meters, in contra-

⁹⁾Altogether twenty for the case of vertical incidence of the muon group on the cloud chamber.

* $\operatorname{tg} = \tan$.

FIG. 6. Distribution of the distances between the trajectories of the muons contained in parallel groups, in the plane of the upper cover of the chamber: 1—experiment, 2—calculation by the Monte Carlo method.

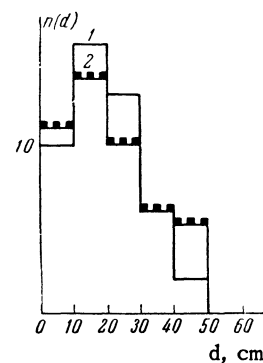

distinction to what holds, in accordance with [2,5], in the case of showers with $N > 10^5$.

It is clear that our experiment cannot yield any information concerning the presence or absence of correlated muons with group diameter $d \geq a$, where a is the characteristic dimension of our array (≈ 0.3 m), since these muons will yield a distribution corresponding to the condition of statistical independence of the muon trajectories.

In conclusion, the authors express their gratitude to N. A. Dobrotin for stimulating interest and attention to the work, A. E. Chudakov for support of the work, valuable advice, and discussion, to N. S. Il'ina, G. D. Davimus, K. K. Khvostov, and A. A. Bednyakov, for participating in the construction and operation of the array, and also to G. T. Zatsypin, S. I. Nikol'skiĭ, and G. B. Khristiansen for participation in the discussion of the results.

¹Higashi, Oshio, Shibata, Watanabe, and Watase, *Nuovo cimento* **5**, 597 (1957); Khigashi, Ishio, Shibata, Vatanabe, and Vataase, *Trans. Intl. Conf. on Cosmic Rays, IUPAP, Moscow, 1960*, vol. 1.

²Vernov, Khrenov, and Khristiansen, *JETP* **37**, 1252 (1959), *Soviet Phys. JETP* **10**, 891 (1960).

³Vernov, Kulikov, Strugal'skiĭ, and Khristiansen, *JETP* **37**, 1193 (1959), *Soviet Phys. JETP* **10**, 848 (1960).

⁴Vernov, Ivanenko, Kulikov, and Khristiansen, *JETP* **39**, 509 (1960), *Soviet Phys. JETP* **12**, 356 (1961).

⁵Vernov, Li, Khrenov, and Khristiansen, *JETP* **42**, 758 (1962), *Soviet Phys. JETP* **15**, 528 (1962).

⁶V. M. Fedorov, *PTÉ* (in press).

⁷V. L. Dadykin, *PTÉ* No. 1, 60 (1962).

⁸S. Z. Belen'kiĭ, *Lavinnye protsessy v kosmicheskikh luchakh* (Cascade Processes in Cosmic Rays), Gostekhizdat 1948.

⁹S. Bennet and K. Griesen, *Phys. Rev.* **124**, 1982 (1961).