

COMPOSITION OF SLOW IONS PRODUCED DURING THE IONIZATION OF GASES BY
NEGATIVE IONS

Ya. M. FOGEL', A. G. KOVAL', Yu. Z. LEVCHENKO, and A. F. KHODYACHIKH

Physico-Technical Institute, Academy of Sciences, Ukrainian S.S.R.

Submitted to JETP editor April 9, 1960

J. Exptl. Theoret. Phys. (U.S.S.R.) **39**, 548-555 (September, 1960)

The composition of slow ions produced by 10 to 50 keV H^- and O^- ions in He, Ne, Ar, Kr, Xe, H_2 , N_2 , and O_2 is analyzed with a mass spectrometer. The data of the present investigation, as well as those of a previous study by the authors in which the total cross sections for positive ion formation were measured, have been employed to calculate the cross sections for ionization involving the detachment of a definite number of electrons from the atom. The effective cross sections for production of slow ions with various charges by H^- and H^+ ions are compared.

INTRODUCTION

WHEN an atom of nuclear charge Z is ionized by negative ions, slow ions are produced with charges from e to Ze . By means of a method of collecting these ions on the plate of a measuring capacitor, the value σ^+ of the total cross section for the production of positive ions can be determined. This type of measurement for the ionization of a number of gases by H^- and O^- ions has been made in our previous work.¹

The cross section σ^+ represents the sum $\sum_{n=1}^Z n\sigma_{0n}^i$, where σ_{0n}^i is the cross section for ionization with the detachment of n electrons from the atom.* It is of interest to measure the cross sections σ_{0n}^i , for which it is necessary to study the charge composition of the slow positive ions that are produced. An investigation of the composition of similar ions when fast positive ions pass through gases has been carried out in a number of experiments by Fedorenko and co-workers.²⁻⁵

Attention should be directed to one important difference in the processes of production of slow positive ions by fast positive and negative ions passing through gases. In the case of positive ions traveling through the gas, a positive ion of given charge is produced as a result of pure ionization processes, and also as a result of electron capture processes or processes of ionization with electron capture.⁶ In this case, the cross sections for the production of slow ions are the sums of the

cross sections of all the above processes. Negative ions cannot capture electrons from the gas particles and, as a result, when negative ions travel through the gas, slow positive ions are produced only in pure ionization processes. This fact makes it of interest to determine the cross sections σ_{0n}^i for negative ions. In the present work, measurements were made of the cross section σ_{0n}^i for the ionization of gases of He, Ne, Ar, Kr, Xe, H_2 , N_2 , and O_2 by 10 to 50 keV H^- and O^- ions.

APPARATUS AND METHOD OF MEASUREMENT

The source of negative ions and the collision chamber in which the interaction between the negative ions and gas particles takes place have been described previously;^{1,7} therefore, we give here only a description of the analyzer of the charges of slow ions (Fig. 1).

The slow positive ions produced in the path of the negative ion beam are accelerated by an electric field towards plate 1 of the third capacitor of the chamber (see Fig. 1 in reference 1), having a 20×20 mm opening covered by a grid with a transmission of 97%. The ions, upon passing through the grid, enter the space between the plate and end plane of electrode 2. This electrode is a tube 18 mm in diameter and 175 mm long. In this space the ions are additionally accelerated by the difference in potential V_a applied between plate 1 and electrode 2. Upon passing through a slit of dimensions 2×10 mm in the end plane of electrode 2, the ions are then focused by the electric field V_f in the gap between electrode 2 and the chamber of the magnetic mass spectrometer 6. Electrode 2

*Here and in what follows, we shall use the notation for cross sections introduced by Fedorenko and Afrosimov.²

FIG. 1. Diagram of charge analyzer.

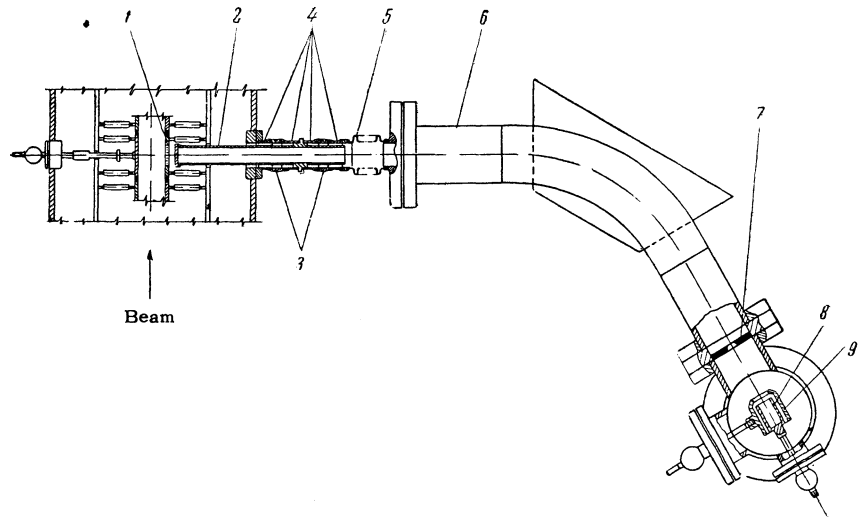

is insulated from the housing of the collision chamber and mass-spectrometer chamber by glass insulators 3 welded to kovar cylinders 4. Electrode 2 is soldered to the middle of these cylinders. The system supporting electrode 2 was joined to the mass-spectrometer chamber through bellows 5, which made it possible to adjust the position of the mass spectrometer with respect to the beam of ions coming from the ionization zone.

The charge analysis of the slow ions was carried out by means of a magnetic mass spectrometer with a beam deflection angle of 60° and a mean trajectory radius of 16.4 cm. The height of the gap between the poles of the electromagnet was 50 mm. The maximum field intensity in the gap was 6000 oe. The brass chamber of the mass spectrometer was insulated from the poles of the electromagnet by two Plexiglas plates 5 mm thick. The measurement of current in the Faraday box 8 at the mass-spectrometer exit was carried out by an ÉMU-3 vacuum-tube electrometer of sensitivity 10^{-14} amp/division. In order to deliver the secondary emission from the Faraday box to electrode 9, a potential of -50 volts was used. In front of the Faraday box was a slit 7, 20 mm high. The slit width could be adjusted from 0 to 20 mm without disturbing the vacuum.

The primary beam current on a Faraday box situated after the exit channel of the collision chamber was measured by a mirror galvanometer of sensitivity 10^{-10} amp/division. The currents in the Faraday box of the mass spectrometer and in the primary beam were measured simultaneously, which substantially reduced the error associated with current fluctuations in the primary beam.

Additional evacuation of the mass-spectrometer chamber was provided on the exit side by an MM-40 oil-diffusion pump, insulated from the

chamber by a porcelain ring 18 mm high. The pressure in the mass-spectrometer chamber when the gas was let into the collision chamber was 5×10^{-6} mm Hg.

The method of determining the slow-ion charge composition will be described here only briefly, since this method is presented in great detail in the article of Fedorenko and Afrosimov.²

The value of σ_{0n}^i was calculated from the formula

$$\sigma_{0n}^i = \alpha_n \sigma^+ / n, \quad (1)$$

where α_n is the relative intensity of the line spectrum of ions of charge n .

As has been shown previously,² the value of α_n correctly describes the actual slow-ion composition in the zone of interaction between the primary beam and the gas only when it is independent of the "extracting" potential difference V_e (potential difference between the condenser plates), V_a , V_f , and the slit width at the mass-spectrometer exit. For each combination of a primary ion with a molecule of the gas and for each primary ion energy, the value of α_n depends on the above-mentioned factors. The working values of V_e , V_a , V_f , and the slit width were chosen on the "plateau" of the respective curves, and were usually equal to the following: $V_e = 100$ volts, $V_a = (0.85 - 1)$ kv, $V_f = (1.25 - 1.5)$ kv, slit width 9 - 20 mm for H^- ions; and $V_e = (150 - 200)$ volts, $V_a = (0.85 - 1.2)$ kv, $V_f = (1.25 - 1.5)$ kv for O^- ions.

To determine the collision chamber gas pressure which would ensure the condition for single collisions, we plotted the ratio $I^{n+}/I_0 = f(p)$ (I^{n+} is the current of ions of charge n , I_0 is the primary beam current), and the working pressure was chosen on the linear part of this curve. Most

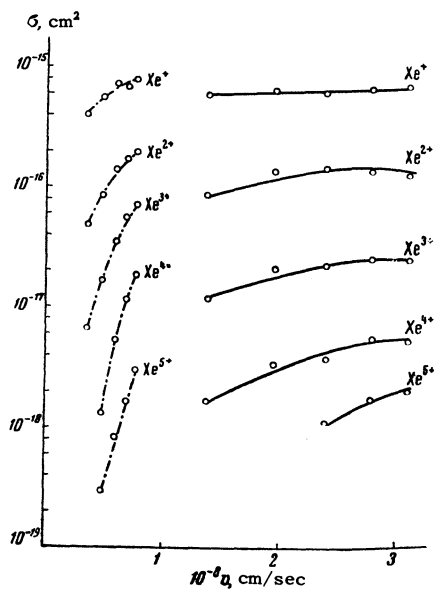

FIG. 2. Variation of cross sections for production of different ions of Xe by fast O^- ions (dash-dot curve) and H^- ions (solid curve); v is the primary ion velocity.

of the measurements were made at a gas pressure of $(1 \text{ to } 1.5) \times 10^{-4}$ mm Hg. The error in the measurement of the value of σ_{0n}^i , consisting of the errors in measurements of the values of σ^+ and α_n , was equal to $\pm 15\%$ for cross sections ($10^{-16} - 10^{-17}$) cm^2 and $\pm 25\%$ for cross sections ($10^{-18} - 10^{-19}$) cm^2 . In order to check the method as a whole, the cross sections for the production of argon ions of charge one to three by 30-keV protons were measured. The results of the measurements agreed with previous results² within the limits of experimental error.

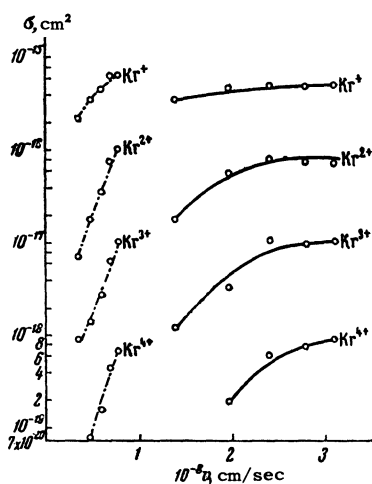

FIG. 3. Cross sections for production of different ions of Kr. Notation the same as in Fig. 2.

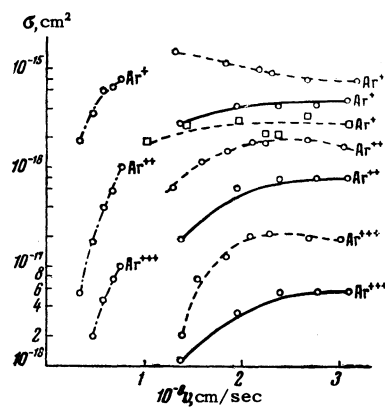

FIG. 4. Cross sections for production of different ions of A by fast O^- ions (dash-dot curve) and H^- ions (solid curve); dotted curve - for the primary H^+ ion (from data of reference 3); $\square - \sigma_{01}^i$ curve (from data of reference 3).

RESULTS OF THE MEASUREMENTS

The dependence of the cross sections σ_{0n}^i on the velocity v of the H^- and O^- ions is shown in Figs. 2 - 6 for the ionization of five inert gases. In the case of Xe, it was possible to measure the cross sections for ions of charge one to three; for Kr, from one to four; for Ar and Ne, from one to three; for He it was, of course, impossible to produce ions of charge greater than two. The velocity dependence of the cross sections σ_{0n}^i was different for H^- and O^- ions. In the case of O^- ions, the cross sections σ_{0n}^i for all gases increase quite rapidly with an increase in the ion velocity. The rate of increase of σ_{0n}^i rises with an increase in the charge multiplicity of the slow ion produced, which is particularly visible on the curves of $\sigma_{0n}^i(v)$ for Xe. The cross sections σ_{0n}^i for H^- ions increase with the ion velocity much more slowly than for O^- ions. For ions of small charge,

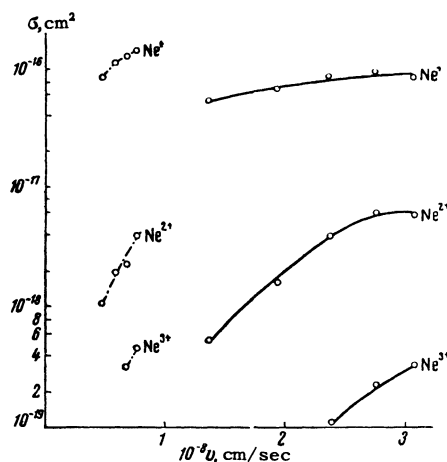

FIG. 5. Cross sections for the production of different ions of Ne.

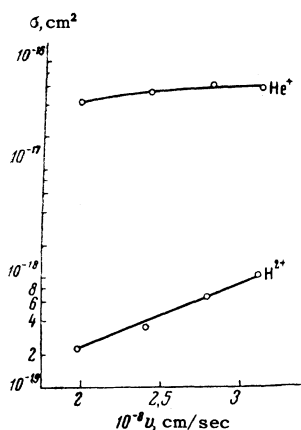

FIG. 6. Cross section for production of ions of He by fast H^- ions.

the $\sigma_{0n}^i(v)$ curves attain a flat maximum. The shape of the $\sigma_{0n}^i(v)$ curves for H^- ions permit one to conclude that the maximum of the curve shifts towards the larger velocities with an increase in the slow-ion charge.

When one considers the $\sigma_{0n}^i(v)$ curves, it should be borne in mind that each cross section σ_{0n}^i is the sum of the cross sections for ionization processes with no change in charge of a negative ion and with the detachment one, two, etc. electrons from a negative ion. Owing to this, the $\sigma_{0n}^i(v)$ curve is the resultant of a number of curves corresponding to the above-mentioned processes. From this viewpoint, the strongly diffused maximum on the $\sigma_{0n}^i(v)$ curves is apparently explained by the fact that the individual curves from whose sum the $\sigma_{0n}^i(v)$ curve is obtained, have maxima at different points.

The cross sections σ_{0n}^i depend on both the type of primary ion and on the type of gas atom.

Although the investigated velocity intervals for H^- and O^- ions do not coincide, one may conclude, however, from consideration of the shape of the $\sigma_{0n}^i(v)$ curves that for the same velocities the cross sections σ_{0n}^i are considerably greater for the O^- ion than for the H^- ion.

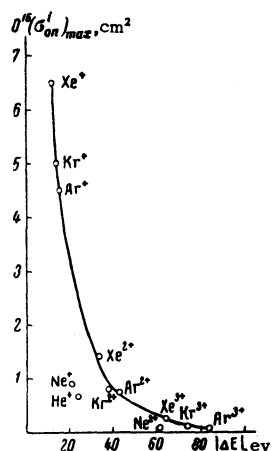

FIG. 7. Maximum cross sections for production of ions versus sum of ionization potentials ΔE .

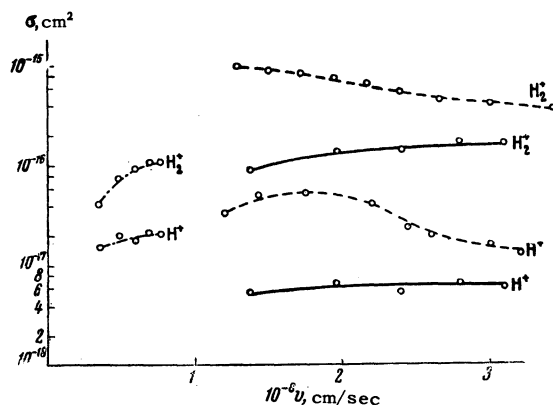

FIG. 8. Cross sections for production of various ions on molecular hydrogen by fast O^- ions (dot-dash curve) and H^- ions (solid curve); dotted curve - for the primary H^+ ion (data of reference 4).

Moreover, the cross section for ionization with the detachment of a given number of electrons increases with an increase in the atomic number of the gas. Thus the dependence of the cross section σ_{0n}^i on the type of primary ion and gas atom is in agreement with the assumption that the ionization cross section increases with an increase in the number of electrons in the electron shells of the colliding particles.

Examination of the $\sigma_{0n}^i(v)$ curves for H^- ions leads to the conclusion that the maximum values $(\sigma_{0n}^i)_{max}$ rapidly decrease with an increase in the multiplicity of ionization, i.e., with an increase in the value of ΔE (ΔE is the sum of the ionization potentials). This circumstance is illustrated in Fig. 7. It is seen that the individual points for the Xe, Kr, and Ar atoms lie nicely on one smooth curve. Points for the Ne and He atoms lie off this curve.

The composition of slow ions produced during the ionization of gas by H^- and O^- ions were also studied for the molecular gases H_2 , N_2 , and O_2 . In the slow-ion spectrum in hydrogen, the ions H_2^+ and H^+ were observed; in nitrogen and oxygen, apart from singly-charged molecular and atomic

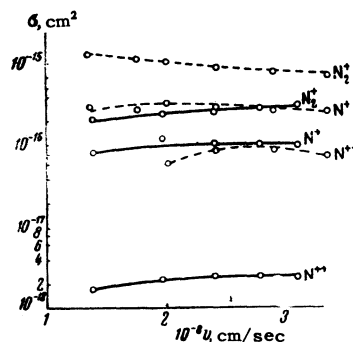

FIG. 9. Cross sections for production of various ions on molecular nitrogen. Solid curve - for H^- ions; dotted curve - for H^+ ions (data of reference 5).

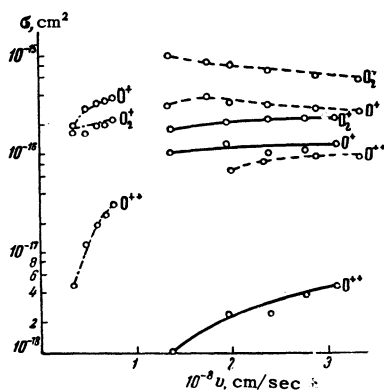

FIG. 10. Cross sections for production of various ions on molecular oxygen. Solid curve – for H^- ions; dotted curve – for H^+ ions (data of reference 5); dot-dash line for O^- ions

ions, doubly-charged atomic ions were also observed. The dependence of the cross section for the production of slow ions on the primary ion velocity is shown in Figs. 8–10. Examination of these curves leads to the following conclusions:

1. In the case of molecular gases, as well as in the case of atomic gases, the ionization cross sections for the same ion velocities are greater for O^- than for H^- ions.

2. The above-mentioned differences in the shape of the cross section curves for ionization of inert gases by H^- and O^- occur when molecular gases are ionized by these ions.

3. For all the investigated pairs, apart from the pair $O^- - O_2$, the cross section for the production of singly-charged molecular ions is greater than the cross section for the production of singly-charged atomic ions, and their ratio for ionization by O^- is less than in the case of H^- ions. The cross sections for the production of doubly-charged ions are much smaller than for singly-charged ions.

The cross sections for the production of singly-charged molecular ions depend comparatively weakly on the type of gas, while the cross section for the production of the H^+ ion is much smaller than for N^+ and O^+ . Similar peculiarities are observed for the production of singly-charged ions of hydrogen, nitrogen, and oxygen by protons.^{4,5}

The cross section for the production of slow ions in Ar, H_2 , N_2 , and O_2 when H^- ions pass through these gases can be compared with the corresponding cross sections for protons measured in references 3–5. From Figs. 4, 9, 10, 11, it is seen that the curves of the cross section for the production of a given slow ion versus the primary ion velocity for protons lie above the corresponding curves for H^- ions and are of different shape. This becomes understandable if one bears in mind that for protons the cross section for the production of a slow ion is the sum of the cross sections for pure ionization and ionization with capture.

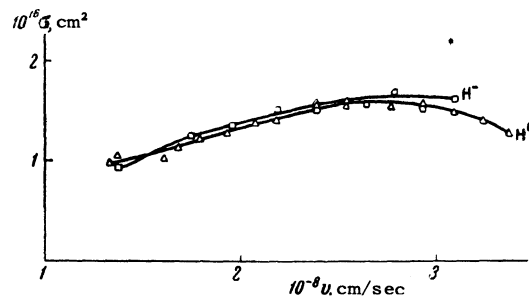

FIG. 11. Total cross sections for ionization of H_2 by H atoms (Δ – data of reference 8) and H^- ions (\square – data of the authors).

A comparison can be made between the cross sections for pure ionization with the production of singly-charged ions by protons and by H^- ions if it is assumed that the cross section for one-electron charge-exchange of protons σ_{01}^{ic} is much greater than the cross sections σ_{02}^{ic} , σ_{03}^{ic} , etc. for charge-exchange processes with simultaneous ionization of the atom.

In fact, (see reference 2)

$$\sigma_{01} = \sigma_{01}^i + \sigma_{01}^{ic}, \quad \sigma_0 = \sigma_{01}^{ic} + \sigma_{02}^{ic} + \sigma_{03}^{ic} + \dots \quad (2)$$

if $\sigma_{01}^{ic} \gg \sigma_{02}^{ic}$ and $\sigma_{01}^{ic} \gg \sigma_{03}^{ic}$, etc., then from formula (2) we obtain

$$\sigma_{01}^i = \sigma_{01} - \sigma_0. \quad (3)$$

The values of the cross section for the production of singly-charged ions (σ_{01}) and the total cross section for electron capture for protons (σ_0) in A were measured by Fedorenko et al.³ The $\sigma_{01}^i(v)$ curve constructed from the data of this work is shown in Fig. 4. Comparison of this curve with the $\sigma_{01}^i(v)$ curve for H^- ions indicates that the cross sections for pure ionization with detachment of one electron for protons and H^- ions do not differ very much from one another. Comparison of the total cross sections for ionization by protons and H^- ions¹ leads to a similar conclusion.

Thus, the difference in the sign of the charge of H^+ and H^- ions does not have a basic effect on the value of the cross sections for ionization by these ions. A slight influence of the charge on the value of the ionization cross sections is confirmed by data in the recent work of Schwirzke,⁸ in which it was shown that the total cross sections for ionization of hydrogen by H atoms and H^+ ions differ from one another by no more than a factor of two.

Using the data of the present work and the data of Schwirzke,⁸ one can compare the total cross sections for ionization of hydrogen by H^- ions and H atoms. Such a comparison is shown in Fig. 11, where plots of the total cross sections for ioniza-

tion of hydrogen versus the velocity of H^- ions and H atoms are shown. The fact that these curves coincide indicates that the influence of the weak binding of the additional electron of the H^- ion on the ionization process of the hydrogen molecule is small.

We express our sincere gratitude to Professor N. V. Fedorenko and V. V. Afrosimov for valuable advice on the method of studying the composition of slow ions produced by fast particles passing through gases, and also to Professor A. K. Val'ter for constant interest in, and attention to, this work.

¹Fogel', Koval', and Levchenko, JETP **38**, 1053 (1960), Soviet Phys. JETP **11**, 760 (1960).

²N. V. Fedorenko and V. V. Afrosimov, J. Tech. Phys. (U.S.S.R.) **26**, 1941 (1956), Soviet Phys.-Tech. Phys. **1**, 1872 (1957).

³Afrosimov, Il'in, and Fedorenko, J. Tech. Phys. (U.S.S.R.) **28**, 2266 (1958), Soviet Phys.-Tech. Phys. **3**, 2080 (1959).

⁴Afrosimov, Il'in, and Fedorenko, JETP **34**, 1398 (1958), Soviet Phys. JETP **7**, 968 (1958).

⁵Il'in, Afrosimov, and Fedorenko, JETP **36**, 41 (1959), Soviet Phys. JETP **9**, 29 (1959).

⁶Fedorenko, Afrosimov, and Kaminker, J. Tech. Phys. (U.S.S.R.) **26**, 1929 (1956), Soviet Phys.-Tech. Phys. **1**, 1861 (1957).

⁷Fogel', Koval', and Timofeev, J. Tech. Phys. (U.S.S.R.) **29**, 1381 (1959), Soviet Phys.-Tech. Phys. **4**, 1270 (1960).

⁸F. Schwirzke, Z. Physik **157**, 510 (1960).

Translated by E. Marquit
109