

emulsion plane has a given direction \mathbf{n} (Fig. 7a). Then it is evident that of the mesons with the given direction \mathbf{n} only those will be recorded which

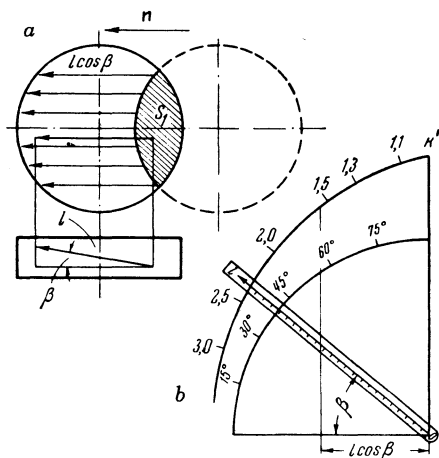

FIG. 7. Nomogram for the edge effect k' .

are produced within the limits of the cross-hatched area S_1 . Since the above consideration does not depend on the choice of the direction \mathbf{n} , then for all the tracks of length l and angle β the edge

effect correction dependent on the finiteness of the chamber diameter will be equal to the ratio of the circle area S to the cross-hatched area S_1 .

$$k' = S/S_1.$$

The determination of the value of k' was made for each track individually with the aid of the nomogram shown in Fig. 7b.

In this manner the true number of produced mesons can be calculated if to each located π -meson one assigns a statistical weight κ equal to the product of the coefficients k and k' ;

$$\kappa = kk'.$$

¹ V. V. Alpers and A. A. Varfolomeeva, *Pribori i Tekhnika Experimenta* 1, 1 (1956).

² Bernardini, Booth and Lindenbaum, *Phys. Rev.* 85, 826 (1952).

³ Blau, Oliver and Smith, *Phys. Rev.* 91, 949 (1953).

Translated by H. Kruglak
216

The Theory of a Fermi Liquid

L. D. LANDAU

Institute for Physical Problems, Academy of Sciences, USSR
(Submitted to JETP editor March 7, 1956)

J. Exptl. Theoret. Phys. (U.S.S.R.) 30, 1058-1064 (June, 1956)

A theory of the Fermi liquid is constructed, based on the representation of the perturbation theory as a functional of the distribution function. The effective mass of the excitation is found, along with the compressibility and the magnetic susceptibility of the Fermi liquid. Expressions are obtained for the momentum and energy flow.

As is well known, the model of a Fermi gas has been employed in a whole series of cases for the consideration of a system of Fermi particles, in spite of the fact that the interaction among such particles is not weak. Electrons in a metal serve as a classic example. Such a state of the theory is unsatisfactory, since it leaves unclear what properties of the gas model correspond to reality and what are intrinsic to such a gas.

For this purpose we must keep in mind that the problem is concerned with definite properties of the energy spectrum ("Fermi type spectrum"), for whose existence it is necessary, but not sufficient

that the particles which compose the system obey Fermi statistics, i.e., that they possess half-integer spin. For example, the atoms of deuterium interact in such a manner that they form molecules. As a result, liquid deuterium possesses an energy spectrum of the Bose type. Thus the presence of a Fermi energy spectrum is connected not only with the properties of the particles, but also with the properties of their interaction.

A liquid of the Bose type was first considered by the author of the present article in application to the properties of He II. It follows from the character of the spectrum of such a liquid that a vis-

ous liquid of Bose particles necessarily possesses superfluid properties. The converse theorem that a liquid consisting of Fermi particles cannot be superfluid, in accord with the above, is in general form not true.

1. THE ENERGY AS A FUNCTIONAL OF THE DISTRIBUTION ENERGY

If we consider a Fermi gas at temperatures which are low in comparison with the temperature of degeneration, and introduce some weak interaction between the atoms of this gas, then, as is known, the collision probability for a given atom, which is found in the diffuse Fermi zone, is proportional not only to the intensity of the interaction, but also to the square of the temperature. This shows that for a given intensity of interaction, the "indeterminacy of the momenta", associated with the finite path length, is also small for low temperatures, not only in comparison with the size of the momentum itself, but also in comparison with the width of the Fermi zone, proportional to the first power of the temperature.

As a basis for the construction of the type of spectrum under consideration, is the assumption that, as we gradually "turn on" the interaction between the atoms, i.e., in the transition from the gas to the liquid, classification of the levels remains invariant. The role of the gas particles in this classification is assumed by the "elementary excitations" (quasi-particles), each of which possesses a definite momentum. They obey Fermi statistics, and their number always coincides with the number of particles in a liquid. The quasi-particle can, in a well-known sense, be considered as a particle in a self-consistent field of surrounding particles. In the presence of a self-consistent field, the energy of the particle depends on the state of the surrounding particles, but the energy of the whole system is no longer equal to the sum of the energies of the individual particles, and is a functional of the distribution function.

We consider an infinitely small change in the distribution function of quasi-particles n . Then we can write down the change in the energy density of the system in the form

$$\delta E = \int \epsilon \delta n d\tau, \quad (1)$$

where $d\tau = dp_x dp_y dp_z / (2\pi\hbar)^3$. The quantity $\epsilon(p)$ is a function of the derivative of the energy with respect to the distribution function. It corresponds to a change in the energy of the system upon the addition of a single quasi-particle with momentum p , and it can be regarded as the Hamiltonian function of the added quasi-particle with

given momentum in the self-consistent field.

However, we have not taken it into account in Eq. (1) that the particles possess spin. Since the spin is a quantum mechanical quantity, it cannot be considered by classical means. We must therefore consider the distribution function of the statistical matrices in regard to spin, and replace Eq. (1) by the following:

$$\delta E = Sp_\sigma \int \epsilon \delta n d\tau, \quad (2)$$

where Sp_σ is the spur over the spin states. The quantity ϵ in the general case is also an operator which depends on the spin operators. If we have an equilibrium liquid, which is not in an external magnetic field, then, because of isotropy, the energy cannot depend on the spin operators. We limit ourselves to the consideration of particles with $s = 1/2$.

We can show that just this energy ϵ enters into the formula for the Fermi distribution of the quasi-particles. Actually, it is reasonable to determine the entropy of the liquid by the following way:

$$S = -Sp_\sigma \int \{n \ln n + (1-n) \ln (1-n)\} d\tau. \quad (3)$$

By means of a variation, subject to the additional conditions

$$\delta N = Sp_\sigma \int \delta n d\tau = 0, \quad \delta E = Sp_\sigma \int \epsilon \delta n d\tau = 0,$$

we can obtain the Fermi distribution

$$n(\epsilon) = [e^{(\epsilon-\mu)/\theta} + 1]^{-1}. \quad (4)$$

from this equation. We note that ϵ , being a functional of n , naturally depends on the temperature also.

In correspondence with (4) the heat capacity of a Fermi liquid at low temperatures will be proportional to the temperature. It is determined by the same formula as for the Fermi gas, with one exception, that in place of the real mass m of the particles therein, we place the effective mass of the quasi-particles

$$m^* = \left. \frac{p}{\partial \epsilon / \partial p} \right|_{p=p_0}, \quad (5)$$

where p_0 is the limiting momentum of the Fermi distribution of quasi-particles at absolute zero.

Not only $\epsilon(p)$ for a given distribution, but also the change in ϵ produced by a change in n , is of essential importance for the theory of the Fermi liquid:

$$\delta \epsilon(p) = Sp_{\sigma'} \int f(p, p') \delta n' d\tau'. \quad (6)$$

Being a second variational derivative, the function f is a symmetric relative to \mathbf{p} and \mathbf{p}' ; moreover, it depends on the spins.

If the principal distribution n is isotropy, then the function f in the general case contains terms of the form $\varphi_{ik}(\mathbf{p}, \mathbf{p}') \sigma_i \sigma'_k$, where σ_i is the spin operator, and if the interaction is exchange, only terms of the form

$$\varphi(\mathbf{p}, \mathbf{p}') (\sigma\sigma').$$

will appear.

We can consider the function f from the following point of view. The number of acts of scattering of quasi-particles per unit volume per unit time can be written in the form

$$dW = \frac{2\pi}{\hbar} |F(\mathbf{p}_1, \mathbf{p}_2; \mathbf{p}'_1, \mathbf{p}'_2)|^2 \delta$$

$$(\varepsilon_1 + \varepsilon_2 - \varepsilon'_1 - \varepsilon'_2) n_1 n_2$$

$$(1 - n'_1)(1 - n'_2) d\tau_1 d\tau_2 d\tau'_1,$$

where conservation of momentum is assumed: $\mathbf{p}_1 + \mathbf{p}_2 = \mathbf{p}'_1 + \mathbf{p}'_2$. The quantity f is nothing else but $-F(\mathbf{p}_1, \mathbf{p}_2; \mathbf{p}'_1, \mathbf{p}'_2)$, i.e., the amplitude of the scattering on 0^0 (with opposite sign). Generally speaking, this amplitude is complex, its imaginary part being determined by the total effective scattering cross section. Inasmuch as we assume that the real acts of scattering are highly improbable, we can neglect the imaginary part.

2. RELATIONS WHICH FOLLOW FROM THE PRINCIPLE OF GALILEAN RELATIVITY

If we deal with a liquid which is not in an external field, then it follows from the principle of Galilean relativity that the momentum arriving at a unit volume must be equal to the density of mass flow*. Inasmuch as the velocity of the quasi-particle is $\partial\varepsilon/\partial\mathbf{p}$, and the number of quasi-particles coincides with the number of real particles, we have

$$S p_\sigma \int \mathbf{p} n d\tau = S p_\sigma \int m \frac{\partial\varepsilon}{\partial\mathbf{p}} n d\tau. \quad (8)$$

* This conclusion does not apply in particular to electrons in a metal. For them, \mathbf{p} is not the momentum, but the quasi-momentum.

Therefore, the variational derivatives with respect to n ought to be the same on both sides of this equation. Then

$$\begin{aligned} \frac{1}{m} S p_\sigma \int \mathbf{p} \delta n d\tau &= S p_\sigma \int \frac{\partial\varepsilon}{\partial\mathbf{p}} \delta n d\tau \\ &+ S p_\sigma S p_{\sigma'} \int \frac{\partial}{\partial\mathbf{p}} f(\mathbf{p}, \mathbf{p}') \delta n' n d\tau d\tau'. \end{aligned}$$

Since the quantity δn is arbitrary, we obtain

$$\begin{aligned} \frac{\mathbf{p}}{m} &= \frac{\partial\varepsilon}{\partial\mathbf{p}} + S p_{\sigma'} \int \frac{\partial f}{\partial\mathbf{p}'} n' d\tau' \\ &= \frac{\partial\varepsilon}{\partial\mathbf{p}} - S p_{\sigma'} \int f \frac{\partial n'}{\partial\mathbf{p}'} d\tau' \end{aligned} \quad (9)$$

(the left side is understood as the unit matrix in the spins).

If we deal with the isotropic case, then it is sufficient that the Eq. (9) hold for the spurs, i.e.,

$$\frac{p}{m} = \frac{\partial\varepsilon}{\partial p} - \frac{1}{2} S p_\sigma S p_{\sigma'} \int f \frac{\partial n'}{\partial p'} d\tau'. \quad (10)$$

We note that this formula determines the function ε through the quantity f with accuracy to within a constant.

Let us consider Eq. (10) for momenta close to the boundary of the Fermi distribution. For low temperatures, the function $\partial n/\partial p$ will differ slightly from the δ -function. For this reason, we can carry out the integration in Eq. (10) over the absolute value of the momentum, leaving only the integration over the angle. This gives the following relation between the real and the effective masses:

$$\frac{1}{m} = \frac{1}{m^*} + \frac{p_0}{2(2\pi\hbar)^3} S p_\sigma S p_{\sigma'} \int f \cos\theta d\Omega. \quad (11)$$

Inasmuch as, in this formula, both of the vector arguments in f correspond to the Fermi surface, the function f depends only on the angle between them.

3. COMPRESSIBILITY OF THE FERMI LIQUID

Let us express the compressibility (at absolute zero) by the more appropriate quantity for us, $\partial\mu/\partial N$. For this purpose, we note that as a consequence of homogeneity, the chemical potential μ depends only on the ratio N/V . Consequently, we have

$$\frac{\partial\mu}{\partial N} = -\frac{V\partial\mu}{N} = -\frac{V^2}{N} \frac{\partial\mu}{\partial V}. \quad (12)$$

For the square of the velocity of sound, we have

$$c^2 = \frac{\partial p}{\partial (mN/V)} = \frac{1}{m} \left(N \frac{\partial \mu}{\partial N} \right). \quad (13)$$

Thus the problem reduces to the calculation of the derivative $\partial \mu / \partial N$. Inasmuch as $\mu = \epsilon(p_0) = \epsilon_0$, the change in the chemical potential $\delta \mu$ which is brought about as a result of the change in the total number of particles δN , will be equal to*

$$\delta \mu = \frac{1}{2} \text{Sp}_\sigma \text{Sp}_{\sigma'} \int f \delta n' d\tau' + \frac{\partial \epsilon_0}{\partial p_0} \delta p_0. \quad (14)$$

The second term is connected with the fact that for a change δN the limiting momentum p_0 changes by an amount δp_0 .

For the case of spin $1/2$, δN and δp_0 are connected by the relation

$$\delta N = 8\pi p_0^2 \delta p_0 V / (2\pi\hbar)^3. \quad (15)$$

The value of the function under the integral in Eq. (14) is appreciable only for values of momentum close to p_0 . Therefore, we can carry out integration over the absolute value of p , obtaining

$$\text{Sp}_\sigma \text{Sp}_{\sigma'} \int f \delta n' d\tau' = \frac{1}{8\pi V} \text{Sp}_\sigma \text{Sp}_{\sigma'} \int f d\omega \delta N. \quad (16)$$

We get from Eq. (14), with the help of Eqs. (15) and (16):

$$\begin{aligned} \partial \mu / \partial N = \text{Sp}_\sigma \text{Sp}_{\sigma'} \int f d\omega / 16\pi V \\ + (2\pi\hbar)^3 / 8\pi p_0 m^* V. \end{aligned} \quad (17)$$

Now let us make use of Eq. (11) and express the effective mass m^* in the expression that has been obtained by the mass of the particles, m . We have

$$\frac{\partial \mu}{\partial N} = \frac{1}{16\pi V} \int \text{Sp}_\sigma \text{Sp}_{\sigma'} f (1 - \cos \theta) d\omega + \frac{(2\pi\hbar)^3}{8\pi p_0 m^* V}.$$

Furthermore, multiplying the resultant equation by $N/m = (1/m) 8\pi p_0^3 V / 3 (2\pi\hbar)^3$, we find an expression for the square of the sound velocity:

$$c^2 = \frac{p_0^2}{3m^2} + \frac{1}{6m} \left(\frac{p_0}{2\pi\hbar} \right)^3 \int \text{Sp}_{\sigma, \sigma'} f (1 - \cos \theta) d\omega. \quad (18)$$

* Equation (14) is obtained as a result of taking the spur of the analogous expression which contains the spin operators.

4. MAGNETIC SUSCEPTIBILITY

We calculate the magnetic susceptibility of a Fermi liquid. If the system is located in a magnetic field \mathbf{H} , then the additional energy of a free particle in this field is equal to $\beta \sigma \mathbf{H}$. Moreover, we must also consider the fact that the form of the distribution function also changes in the presence of a magnetic field. Consequently, in calculating the magnetic susceptibility, we must keep in mind that

$$\delta \varepsilon = -\beta (\sigma \mathbf{H}) + \text{Sp}_{\sigma'} \int f \delta n' d\tau', \quad (19)$$

i.e., it is impossible to neglect the effect of the term containing f . We write f in the form

$$f = \varphi + \psi(\sigma \sigma'), \quad (20)$$

where the second term takes into account the exchange interaction between the particle s . Furthermore, in calculating δn , which depends on the field, the change in the chemical potential $\delta \mu$ does not have to be considered. This change appears as a quantity of second order of smallness relative to the field \mathbf{H} , while $\delta \epsilon$ is of first order with respect to the field. Therefore, we can substitute $\delta n = (\partial n / \partial \epsilon) \delta \epsilon$ in Eq. (19). We then have

$$\delta \varepsilon = -\beta (\sigma \mathbf{H}) + \text{Sp}_{\sigma'} \int f \frac{\partial n'}{\partial \varepsilon'} \delta \varepsilon' d\tau'. \quad (21)$$

We shall look for $\delta \epsilon$ in the form

$$\delta \varepsilon = -\gamma (\sigma \mathbf{H}). \quad (22)$$

The quantity γ is defined by Eq. (21)*

$$\gamma = \beta + \frac{1}{2} \int \psi \frac{\partial n}{\partial \varepsilon'} \gamma' d\tau'. \quad (23)$$

Remembering the δ -character of $\partial n / \partial \varepsilon$, we then obtain

$$\gamma = \beta - \frac{1}{2} \bar{\psi}_0 \gamma (\partial \tau / \partial \varepsilon)_0. \quad (24)$$

Here the index zero indicates that the values of all functions are taken at $p = p_0$; the bar over the symbol indicates averaging over the angles. On the other hand, the susceptibility is defined by the relation

$$\chi \mathbf{H} = \beta \text{Sp} \int n \sigma d\tau$$

* Here we make use of the relation $\text{Sp}_{\sigma'} (\sigma \sigma') \sigma' = 1/3 \sigma \text{Sp}_{\sigma'} (\sigma' \sigma') = 1/2 \sigma$.

or

$$\chi \mathbf{H} = -\beta \text{Sp} \int \frac{\partial \tau}{\partial \varepsilon} \gamma (\mathbf{H} \sigma) \sigma d\tau = \frac{\mathbf{H}}{2} \beta \gamma \left(\frac{d\tau}{d\varepsilon} \right)_0 \quad (25)$$

Hence, we get finally,

$$\frac{1}{\chi} = \frac{2}{\beta \gamma_0 (\partial \tau / \partial \varepsilon)_0} \quad (26)$$

$$= \frac{2}{\beta^2 (d\tau / d\varepsilon)_0} \left(1 + \frac{1}{2} \overline{\psi_0} \left(\frac{d\tau}{d\varepsilon} \right)_0 \right).$$

Further, we can replace $(d\tau / d\varepsilon)_0$ by the coefficient α in the linear heat capacity law. Then

$$1/\chi = \beta^{-2} \{ 2\pi^2 k^2 / 3\alpha + \overline{\psi_0} \}. \quad (27)$$

It is then evident that there does not exist in the liquid the relation between the heat capacity and the susceptibility that exists in gases. The term with $\overline{\psi_0}$ takes the exchange interaction into account and is large for liquids. Thus, for He^3 , analysis of the experimental data¹ shows that $\overline{\psi_0}$ is negative and amounts to about 2/3 of the first term.

5. THE KINETIC EQUATION

In the absence of a magnetic field and for a neglect of the magnetic spin-orbit interaction, ϵ does not depend on the operator σ and the kinetic equation in the quasi-classical approximation takes the form

$$\frac{\partial n}{\partial t} + \frac{\partial n}{\partial \mathbf{r}} \frac{\partial \varepsilon}{\partial \mathbf{p}} - \frac{\partial n}{\partial \mathbf{p}} \frac{\partial \varepsilon}{\partial \mathbf{r}} = I(n). \quad (28)$$

The necessity of calculation of derivatives of the energy ϵ with respect to the coordinates in the absence of an external field is connected with the fact that ϵ is a functional of n , and the distribution function n depends on the coordinates.

We find the expression for the momentum flux. For this purpose, we multiply the left and right sides of the equation above by the momentum p_i and integrate over all phase space. We have

$$\frac{\partial}{\partial t} \text{Sp} \int p_i n d\tau + \text{Sp} \int p_i \left(\frac{\partial n}{\partial x_k} \frac{\partial \varepsilon}{\partial p_k} - \frac{\partial n}{\partial p_k} \frac{\partial \varepsilon}{\partial x_k} \right) d\tau \quad (29)$$

$$= \text{Sp} \int p_i I(n) d\tau.$$

As a consequence of the conservation of momentum for collisions, the right side of the equation is zero, while the left side yields, after simple transformations,

$$\frac{\partial}{\partial t} \int p_i n d\tau + \frac{\partial}{\partial x_k} \int p_i \frac{\partial \varepsilon}{\partial p_k} n d\tau$$

$$- \int p_i \frac{\partial}{\partial p_k} \left(n \frac{\partial \varepsilon}{\partial x_k} \right) d\tau = 0. \quad (30)$$

Finally, integrating the three integrals by parts, we get

$$\frac{\partial}{\partial t} \int p_i n d\tau + \frac{\partial}{\partial x_k} \int p_i \frac{\partial \varepsilon}{\partial p_k} n d\tau \quad (31)$$

$$+ \int n \frac{\partial \varepsilon}{\partial x_i} d\tau = 0.$$

The integral $\text{Sp} \int n (\partial \epsilon / \partial x_i) d\tau$ can be represented in the form [see (2)]

$$\text{Sp} \int n \frac{\partial \varepsilon}{\partial x_i} d\tau = \text{Sp} \frac{\partial}{\partial x_i} \int n \varepsilon d\tau - \text{Sp} \int \varepsilon \frac{\partial n}{\partial x_i} d\tau$$

$$= \frac{\partial}{\partial x_i} [\text{Sp} \int n \varepsilon d\tau - E].$$

Thus we finally obtain the law of conservation of momentum:

$$\frac{\partial}{\partial t} \text{Sp} \int p_i n d\tau + \frac{\partial \Pi_{ik}}{\partial x_k} = 0, \quad (32)$$

where the tensor of momentum flux is

$$\Pi_{ik} = \text{Sp} \int p_i \frac{\partial \varepsilon}{\partial p_k} n d\tau + \delta_{ik} [\text{Sp} \int n \varepsilon d\tau - E]. \quad (33)$$

In a similar way we obtain the expression for the energy flow. We multiply the left and right sides of the kinetic equation (28) by ϵ and integrate over all phase space. We have

$$\text{Sp} \int \varepsilon \frac{\partial n}{\partial t} d\tau + \text{Sp} \int \varepsilon \left(\frac{\partial n}{\partial \mathbf{r}} \frac{\partial \varepsilon}{\partial \mathbf{p}} - \frac{\partial n}{\partial \mathbf{p}} \frac{\partial \varepsilon}{\partial \mathbf{r}} \right) d\tau$$

$$= \text{Sp} \int \varepsilon I(n) d\tau.$$

As a consequence of the conservation of energy under collisions, the right side is zero while the left side reduces without difficulty to the form

$$\int \varepsilon \frac{\partial n}{\partial t} d\tau + \frac{\partial}{\partial \mathbf{r}} \int n \varepsilon \frac{\partial \varepsilon}{\partial \mathbf{p}} d\tau = 0.$$

Taking Eq. (2) into account, we have finally,

$$\frac{\partial E}{\partial t} + \text{div } \mathbf{Q} = 0, \quad (34)$$

where the energy flow is

$$Q = \text{Sp} \int n_s \frac{\partial \epsilon}{\partial \mathbf{p}} d\tau. \quad (35)$$

In the solution of concrete kinetic problems it is necessary to keep in mind the following circumstances. For such a solution we usually write down the function n in the form of a sum of equilibrium functions n_0 and correction δn . In this case the departure of the tensor of momentum flow Π_{ik} and the vector of energy flow Q from their equilibrium values will result as a consequence of the

direct change of the function n by the quantity δn , as well as from the change in ϵ which comes about as a result of the functional dependence of ϵ on n [Eq. (2)].

In conclusion, I express my gratitude to I. M. Khalatnikov and A. A. Abrikosov for fruitful discussions.

¹ Fairbank, Ard and Walters, Phys. Rev. 95, 566 (1954).